

技术参数:

- 插针数: 12
- 额定电流
 信号针: 7A
- 额定电压: 25V~ /60V-
- 额定脉冲电压: 1.5KV
- 污染等级: 3
- 绝缘电阻: $\geq 10^{12}\Omega$
- 温度范围: $-40^{\circ}\text{C} \dots +115^{\circ}\text{C}$
- 阻燃等级: V0 (UL94)
- 接触电阻: $\leq 5\text{m}\Omega$
- 插拔次数: ≥ 100
- 插体材料: PBT
- 接线方式: 冷压连接
- 导线截面规格:
 -D-Sub区: $0.09-0.82\text{mm}^2(28-18\text{AWG})$

须单独订购冷压针

Technical specification:

- Number of contacts: 12
- Rated current
 signal contact: 7A
- Rated voltage: 25V~ /60V-
- Rated impulse voltage: 1.5KV
- Pollution degree: 3
- Insulation resistance: $\geq 10^{12}\Omega$
- Temperature range: $-40^{\circ}\text{C} \dots +115^{\circ}\text{C}$
- Flammability acc.to UL94: V0 (UL94)
- Contact resistance: $\leq 5\text{m}\Omega$
- Mating cycles: ≥ 100
- Material of insert: PBT
- Terminal: Crimp termination
- Wire gauge:
 -D-Sub contact: $0.09-0.82\text{mm}^2(28-18\text{AWG})$

Order crimp contacts separately

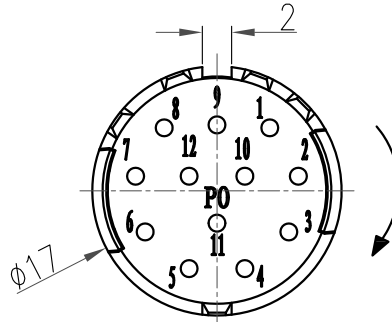

触点排列: 配合面
Contact arrangement: mating side

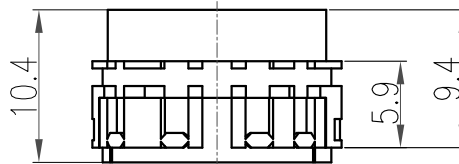
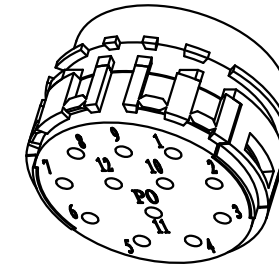

| | | | | | | | | | | | |
|---------------|--------------|------------------|----------------|-----------------|------------|---|-------------|---|-------------------|-------------|------------------|
| | | | | | | 表面处理 Finish | - | | 图号 Drawing No. | - | |
| | | | | | | 材料 Material | - | | 产品代号 Part Code | HR23-012-MC | |
| 标记 Mark | 处数 Number | 变更描述/Description | | 签名 Signature | 日期 Date | | 比例 Scale | 版本 REV. | 重量 Weight | 数量 Qty. | 产品料号 Part No. |
| 绘图 Drawn | 姓名/Name | 日期/Date | 标准化 Stand. | 姓名/Name | 日期/Date | 2:1 | | | | | V1.0 |
| 审核 Checked | ZM LIN | 04.05.2016 | | | | | | | | | |
| 工艺 Process | - | - | 批准 Approved | YY LUO | 04.05.2016 | All Dimensions in mm Original Size DIN A 4 | | 厦门唯恩电气有限公司 XIAMEN WAIN ELECTRICAL CO.LTD | | | |